

### General Description

NS73 is a FM stereo transmitter IC for the applications such as wireless Microphone, MP3, CD, cellular phone.

### Features

- Transmitting frequency Coverage
  - 87.5MHz to 108MHz
- Stereo modulator with 19kHz pilot tone
- 32.768kHz crystal oscillation support
- Package size : 3.26 x 3.26 x 0.79mm (typ.)
- Package weight : 1.8mg (typ.)
- Less external components - size below 1005 except power de-coupling Capacitor
- External reference frequency input available
- MOS Varactor for local oscillator implemented
- Alignment-free
- I<sup>2</sup>C bus or 3-wire serial interface with MCU
- Operating Voltage = 2.7V to 3.6V (3.0V typ.)
- Operating Temperature = -30degC to +80degC
- Full CMOS process

### Operating Conditions

ITEM	SYMBOL	MIN.	TYP.	MAX.	UNIT
Operating Voltage	VDD	2.7	3.0	3.6	V
Operating Temperature	Ta	-30		+80	degC
Storage Temperature	Tstg	-40		+125	degC

### Electrical Performance

VDD = 3.0V±0.05V, Ta = 25degC, f-AF = 1kHz, Vi-AF = 90mVrms, otherwise specified

PARAMETER	SYM	CONDITION	MIN	TYP	MAX	UNIT
Current Consumption	I <sub>dd</sub>			36	45	mA
Standby Current	I <sub>stb</sub>			1.5	20	uA
Input Low level Voltage	ViL	IIC, LA,DA, CK pins	-0.3	0	0.25 * VDD	V
Input High Level Voltage	ViH	IIC, LA,DA, CK pins	0.75 * VDD	VDD	VDD + 0.3	V
Output Low Level Voltage	VoL	DA pin IoL = -3mA	0		0.4	V
TX Frequency	f <sub>TX</sub>		87.5		108	MHz
TX Power Output	PO	RI = 50-ohm, fo = 90MHz		1 or 2		mW
Modulation Deviation	Dev	Pre-emphasis = on	+/-50			kHz
Modulation Distortion(Mono)	THD			0.4	1.0	%
Modulation SN Ratio	SNR		50	55		dB
Stereo Separation	SEP		25	35		dB
Audio Freq. Response	FR	f = 50Hz - 15kHz fi = 400Hz@0dB Vi = 12mVrms	-3	0	1.5	dB
Audio input impedance	Z <sub>af</sub>	f = 50Hz - 15kHz	50	60		kohm
Pilot Tone Level	PL		9	10	11	%
Crystal Frequency	f <sub>X</sub> T			32.768		kHz
Crystal Tolerance	d <sub>X</sub> T	Ta = 25degC VDD=2.7V - 3.6V	-20	0	20	ppm

## Applications

- Wireless Microphone
- Portable CD and MP-3 embedded
- Cellular phone embedded

**Note: Transmission performance should be followed by Regulations or Rule of each country.**

## Block Diagram

**Block Diagram of NS73**

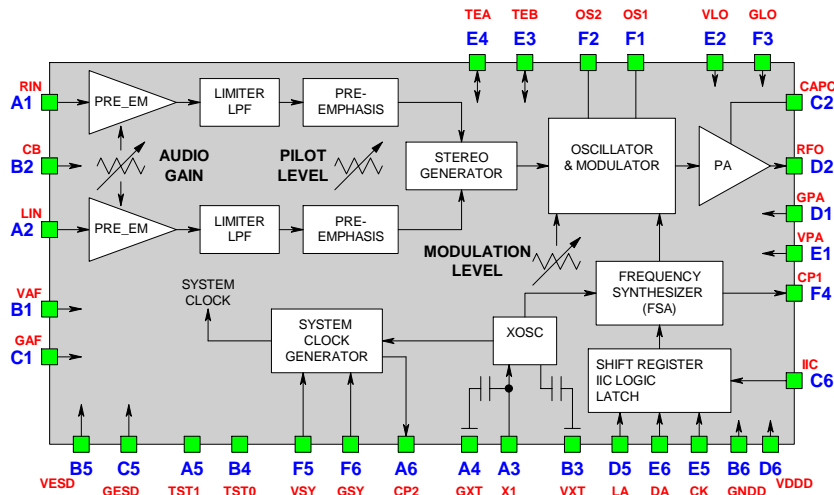

## Pin Allocation

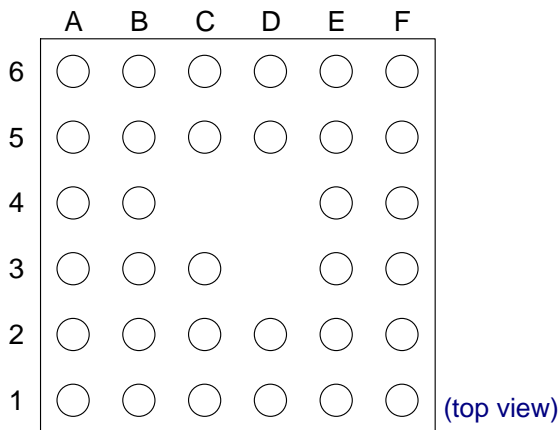

PIN	NAME	I, O	DESCRIPTION
B6	GNDD	-	Ground for Digital
C1	GAF	-	Audio Ground
C2	CAPC	I	Smoothing Capacitor for APC
C3	NC	-	Non Connection
C5	GESD	-	Ground
C6	IIC	I	I <sup>2</sup> C or 3-wire I/F selector 0=3-wire, 1=I <sup>2</sup> C
D1	GPA	-	RF Power amp Ground
D2	RFO	O	RF Power output
D5	LA	I	Latch for 3-wire or Address for I <sup>2</sup> C
D6	VDDD	-	Digital VDD
E1	VPA	-	RF Power amp VDD
E2	VLO	-	LO VDD
E3	TEB	O	Unlock detect output
E4	TEA	O	PE output
E5	CK	I	Clock input for I/F (Pull up R needed)
E6	DA	I/O	Data I/O for I/F (Pull up R needed)
F1	OS1	O	LO tank circuit-1
F2	OS2	O	LO tank circuit-2
F3	GLO	-	LO Ground
F4	CP1	O	Charge Pump output for Main Synthesizer
F5	VSY	-	VDD for Synthesizer
F6	GSY	-	Ground for Synthesizer

PIN	NAME	I, O	DESCRIPTION
A1	RIN	I	Audio Right signal input
A2	LIN	I	Audio Left signal input
A3	X1	I	Crystal input
A4	GXT	-	Ground for Crystal
A5	TST1	O	Test output
A6	CP2	O	Charge Pump output for Clock Gen.
B1	VAF	-	Audio VDD
B2	CB	I	De-coupling Capacitor for VDD/2
B3	VXT	-	VDD for Crystal
B4	TST0	I	Test input
B5	VESD	-	VDD

Note: For further information, please contact our sales department.



**NIIGATA SEIMITSU CO., LTD.**

Shiba Daimon, 116Bldg.8F, 16-3, 1Chome Shiba Daimon, Minatoku, Tokyo, Japan  
<http://www.niigata-s.co.jp> TEL : 81-3-3437-3570 FAX : 81-3-3437-5622

2006/03/30